

Top[®]

AUTOMAZIONI

BAR FEEDERS & AUTOMATIONS



**NO MORE REASONS
TO WAIT**

FUSION

**SUITABLE FOR FIXED-HEAD CNC LATHES
WITH SPINDLE CAPACITY FROM 6 mm
(0.23") TO 52 mm (2.04")***

**SELF-ADJUSTING GUIDE CHANNEL VIA
THE HMI PANEL**

**NO ADDITIONAL GUIDE CHANNEL
SETS REQUIRED**

**AVAILABLE IN 2100 mm (6.5'),
3200 mm (10.5'), 4100 mm
(13') AND 6100 mm (20') BAR
LENGTH CAPACITIES**



*The minimum and maximum values are set according to the lathe model.

BAR FEEDER LAYOUT

SERIES	A	B	C
2100	3445	3000	412
3200	4375	3200	576
4100	5380	4200	481
6100	7381	6200	597

STORAGE	D
Single level	900
Multi level	1222
Low Single Rack L.700 mm	1610
Bundle	1756

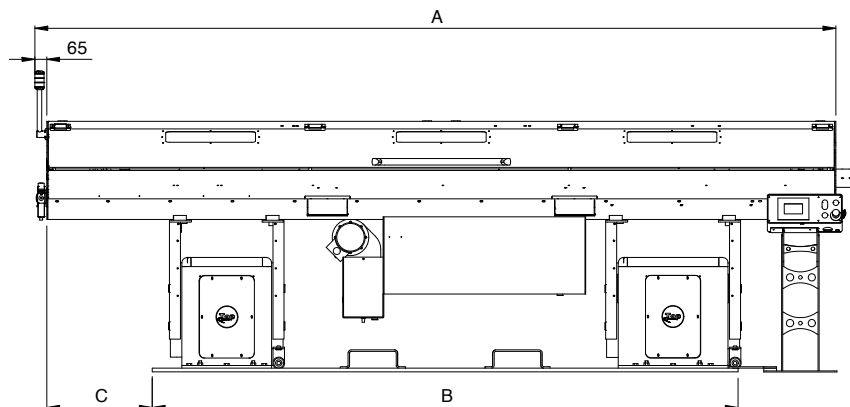
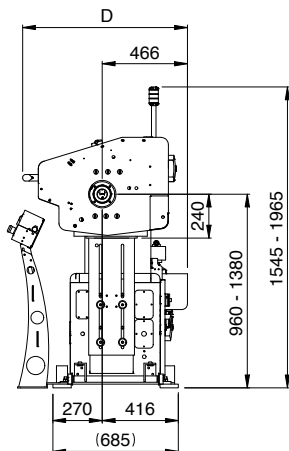



Scan the QR CODE to watch the video

Top
AUTOMAZIONI



FUSION

TECHNICAL DATA	
	FUSION
∅ ROUND BARS	6 mm - 52 mm / 0.23" - 2.04"
∅ HEXAGONAL BARS	6 mm - 45 mm / 0.23" - 1.77"
∅ SQUARE BARS	6 mm - 37 mm / 0.23" - 1.45"
⇕ BAR LENGTH	1200 mm - 3200 mm / 47.24" - 125.98" 1200 mm - 4100 mm / 47.24" - 161.41" 1200 mm - 6100 mm / 47.24" - 240.15"
⌚ MAX FEED SPEED	30 m/min / 98.42'/min
⇕ MAX REMNANT LENGTH	300 mm / 11.81"
🌀 AIR PRESSURE REQUIRED	6.5 - 7.5 bar



SELF ADJUSTING GUIDE CHANNEL

Thanks to the Top Automazioni Patent, FUSION features a self-adjusting guide channel (mm per mm) managed by the PLC. The guide channel is entirely made in vulcanized rubber (Vulkollan). The bars are dipped in an oil bath while processing.

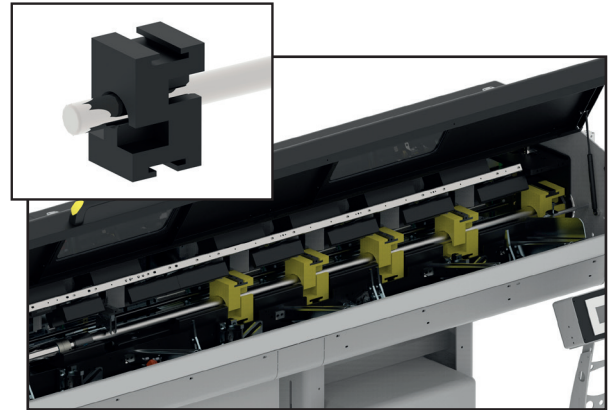

EXTRA STEADY BLOCK

On demand it's possible to apply to the FUSION an external steady block system, suitable for the small diameter bars. The steady block, in fact, will self-activate for any diameter below 20mm (0.78").

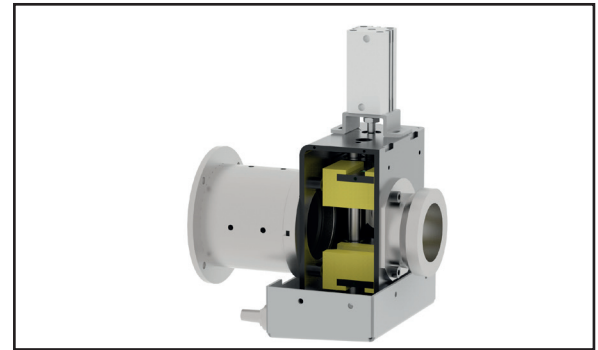

REMNANT EXTRACTION

FUSION offers two different remnant managements:

- 1) Rear extraction performed by means of a self centering extractor
- 2) Front ejection

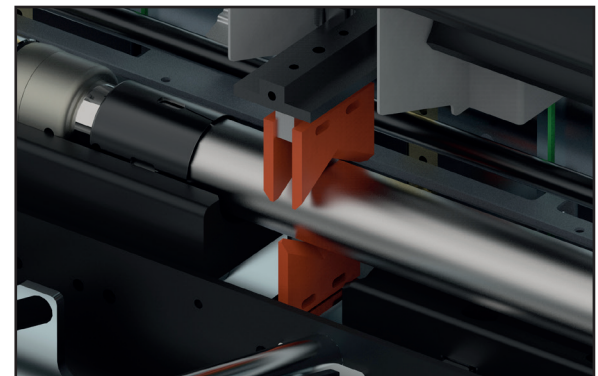

REPOSITIONING SYSTEM

FUSION doesn't require the spindle liner, but it's anyway equipped with a rail system that enables axial 600 mm (23.62") or radial 600 mm (23.62") displacement (alternative option), helping the lathe servicing.



AUTOMATIC MANAGEMENT

The FUSION bar feeder is completely managed by a touch screen PLC interacting with a Brushless motor and a digital pneumatic valves system which controls speed, thrust and all the automations. From the PLC the operator can shift from one diameter to another one IN 60 SECONDS, simply entering the intended diameter on the keyboard.



FUSION

BAR STORAGE

The FUSION can be equipped with 4 different loading storages:

- 1) **SINGLE LEVEL** magazine, featuring a single storage with 235 mm (9.25") carrying capacity
- 2) **MULTI LEVEL** magazine, featuring 3 different levels, each with 300 mm (11.81") carrying capacity
- 3) **FORK LIFTER** magazine, featuring a 700 mm (27.55") double fork loader.
- 4) **BUNDLE**, which supports up to 2 ton (4.409 lbs) of weight



SINGLE LEVEL

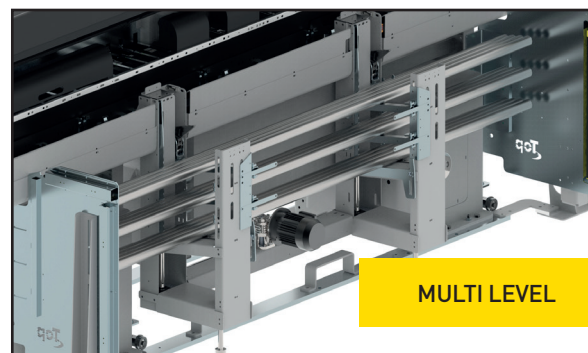

MULTI LEVEL

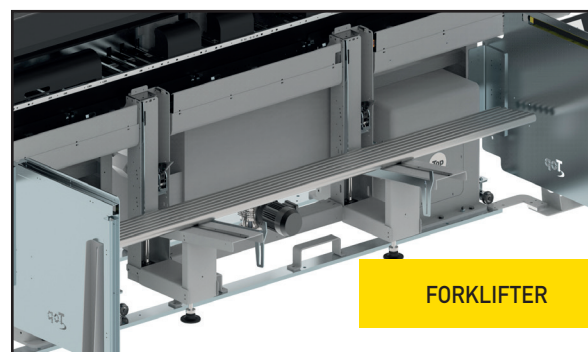

FORKLIFTER



BUNDLE



HOW TO FIND US ►
scan QR code



TOP AUTOMAZIONI S.R.L.

Via Torrianese, 62
47824 Poggio Torriana (RN)

Tel. +39 0541 688248

Fax +39 0541 688168

topautomazioni@topautomazioni.com

www.topautomazioni.com

