



# Hi-TECH 550BB/700BB/700BB<sup>+</sup> 850BB/850BB<sup>+</sup>

High Rigid Big Bore Turning Centers



# HIGH RIGID BIG BORE TURNING CENTERS

The extra scale through-spindles incorporated in the BB-series turning centers are built for turning those extra-length applications, such as the oil pipes. The heavy duty dual air chucks sitting in front and back of the spindle provides extra stability for increased productivity.



# HIGH PERFORMANCE EXTRA-LARGE BIG BORE TURNING CENTERS

### Line-Up

- Hi-TECH 550BB/550BBL
- Hi-TECH 700BB
- Hi-TECH 700BB<sup>+</sup>
- Hi-TECH 850BB/850BBL
- Hi-TECH 850BB<sup>+</sup>/850BB<sup>+</sup>L

### Bar Size

- Ø180 (Ø7.08")
- Ø180 (Ø7.08")
- Ø295 (Ø11.61")
- Ø295 (Ø11.61")
- Ø370 (Ø14.57")

1 Drill Casing Adaptor/Oil Field    2 Steel Oil Pipe/Oil Field  
3 Drill Pipes for Oil and Gas/Oil Field    4 Land-Based Oil Rigs

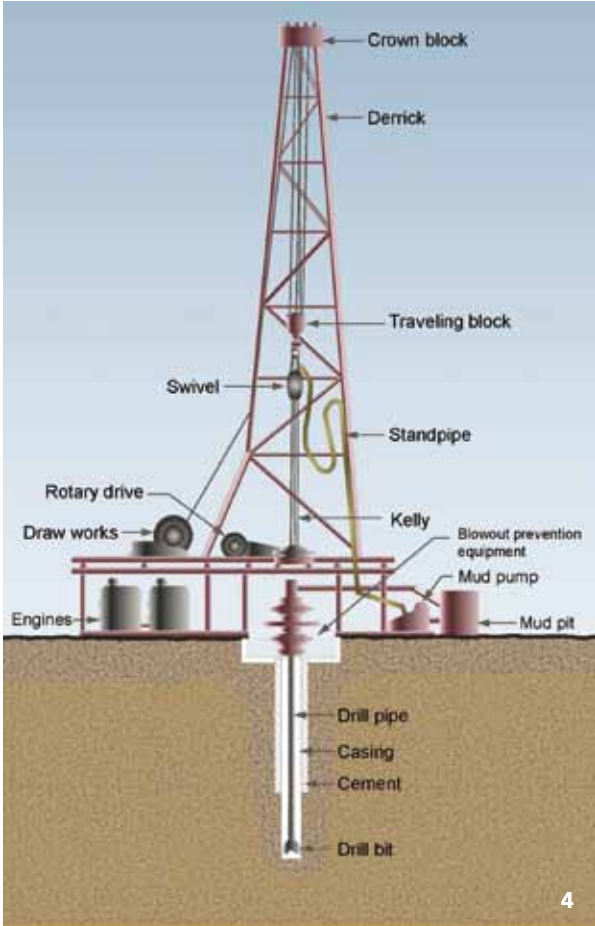

# THE HI-TECH BB SERIES OF BOX-WAY, GEAR-BOX BIG BORE TURNING SOLUTIONS

Hwacheon's Hi-TECH 550BB, 700BB, 700BB+, 850BB, and 850BB+ turning centers are designed for most demanding industrial applications. These tough, highly precise machines employ extra-scale through-spindles, and the two heavy duty air chucks in front and rear of the spindle guarantee perfect results, every time.

The 45-degree tilt unibody bed equipped in each model is ideal for most demanding hard-turning jobs, and the Hi-TECH BB series turning centers employ the box way design in all guide surfaces for maximum stability and precision after hours of prolonged operation. The gear-transmission spindle assembly provides both low-torque and high speed turning enable increased productivity.





# HIGH RIGID BIG BORE SPINDLE FOR OIL PIPE

Hwacheon provides you many different model options so you can have the right tool for your extra-length turning jobs and be more efficient. Choose from a  $\varnothing 470$ ,  $\varnothing 630$ , or  $\varnothing 850$  air chuck, or a manual chuck, to suit your applications.



Optional manual chuck in the back

This wide through-spindle is perfect for oil pipe machining and other long shaft applications.



Optional air chuck in front

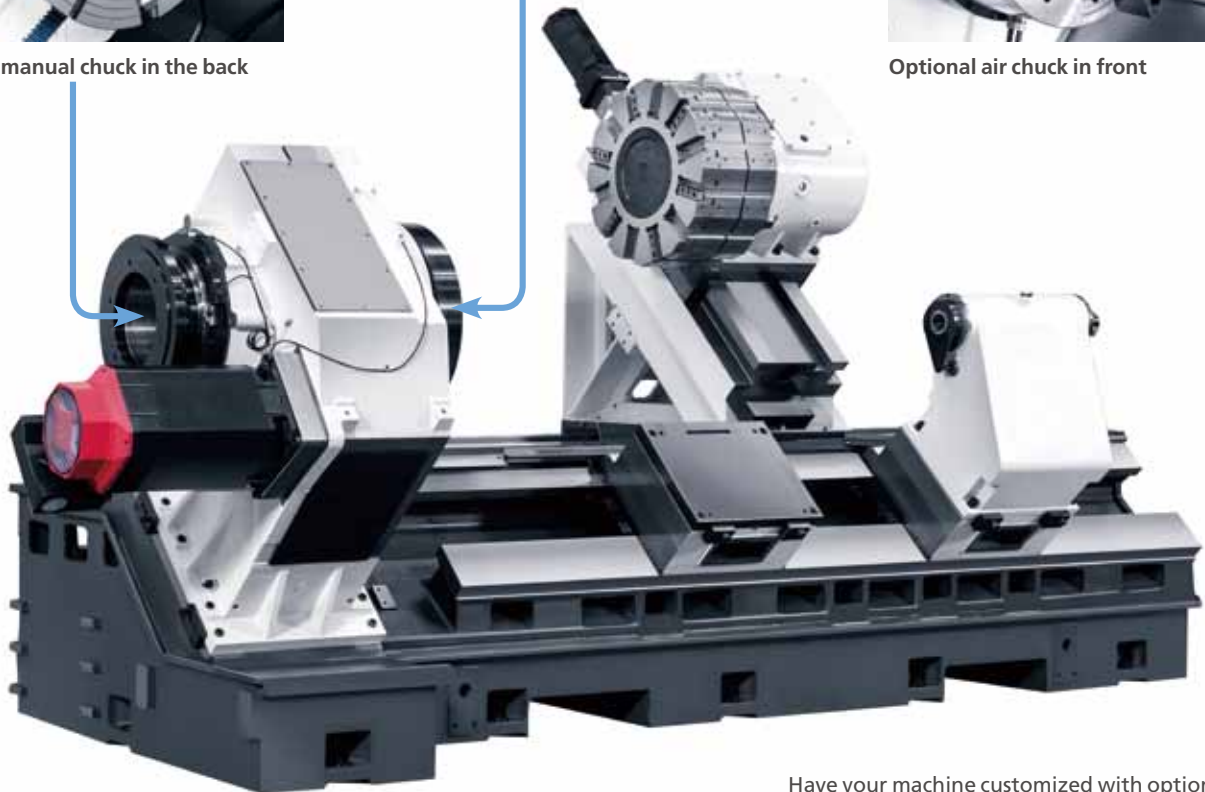

Have your machine customized with optional air chucks for even higher stability and precision.

\* Unit: mm(inch)

	Hi-TECH 550BB	Hi-TECH 700BB	Hi-TECH 700BB <sup>+</sup>	Hi-TECH 850BB	Hi-TECH 850BB <sup>+</sup>
Maximum Turning Diameter	$\varnothing 590(\varnothing 23.23")$	$\varnothing 650(\varnothing 25.59")$	$\varnothing 700(\varnothing 27.56")$	$\varnothing 920(\varnothing 36.22")$	$\varnothing 920(\varnothing 36.22")$
Chuck Size	$\varnothing 470(\varnothing 18.5")$	$\varnothing 470(\varnothing 18.5")$	$\varnothing 630(\varnothing 24.8")$	$\varnothing 630(\varnothing 24.8")$	$\varnothing 850(\varnothing 33.47")$
Through Spindle Hole Diameter	$\varnothing 185(\varnothing 7.28")$	$\varnothing 185(\varnothing 7.28")$	$\varnothing 300(\varnothing 11.81")$	$\varnothing 300(\varnothing 11.81")$	$\varnothing 375(\varnothing 14.76")$
Maximum Bar Size	$\varnothing 180(\varnothing 7.08")$	$\varnothing 180(\varnothing 7.08")$	$\varnothing 295(\varnothing 11.61")$	$\varnothing 295(\varnothing 11.61")$	$\varnothing 370(\varnothing 14.57")$

**High Performance Spindle**

This performance spindle delivers high torque at low speed, while the internal gear array provides efficient braking power, along with the built-in high-performance brake. The bearings inside the spindle assembly are oil cooled, with Hwacheon's unique Oil Jet Cooling technology; and the gearbox temperature is efficiently regulated with the circulating oil coolant, for precision results at all time. This spindle system is specially effective for large size, heavy duty jobs.

- Hi-TECH 550BB: Grease Type
- Hi-TECH 700BB, 700BB\*: Oil-Jet Type
- Hi-TECH 850BB, 850BB\*: Oil-Jet Type

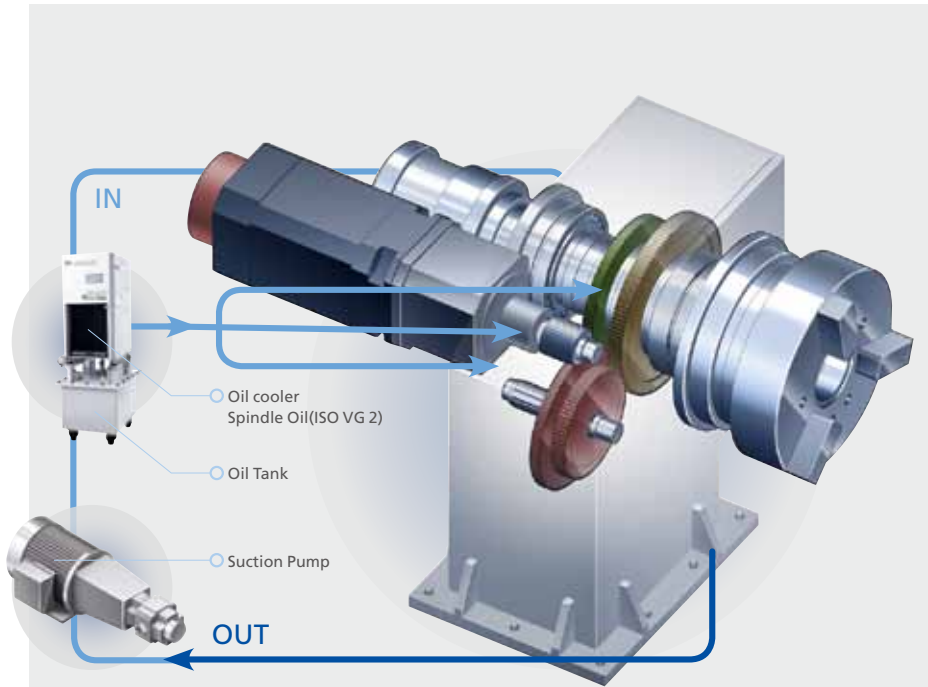

**High Performance Turret**

Y axis can be added per your request; and the entire process from turning to milling can be performed with a single setting. This helps maintain your quality, and eliminates down time in between jobs by getting rid of unnecessary loading and unloading of work pieces. It's like having two machines in one, which means you'll be twice as productive.

**Max. Long Borning Bar Size (D x L)**

- Hi-TECH 550BB: Ø60 x 480mm  
- Opt.: Wide Type Turret Disk
- Hi-TECH 700BB/700BB\*: Ø60 x 600mm  
- Opt.: Wide Type Turret Disk
- Hi-TECH 850BB/850BB\*: Ø80 x 800mm  
- Std.: Wide Type Turret Disk

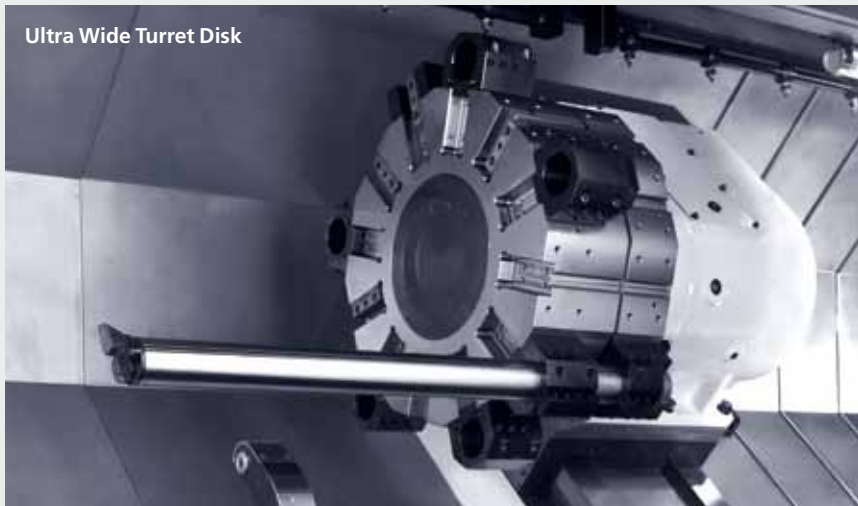

**Multitasking**

Run by a powerful AC spindle motor, the turnmill can accurately axis-index the spindle to perfectly mill, tap, or drill. Different types of milling or turning job can be performed with a single chucking when the optional Y axis is installed.







# USER FRIENDLY DESIGN, A WIDE RANGE OF OPTIONAL FEATURES

The BB-series turning centers are designed with end users in mind. Its user-friendly machine design and a variety of supplementary features ensure a stronger, faster and more precise machining performance.

### Accessibility translates to productivity.

The side cover is designed to let hoist lifted large work pieces to be loaded and unloaded from the rear of the spindle, to maximize accessibility.



### L-HTLD: Hwacheon Lathe Tool Load Detect System (Option)



The Hwacheon Lathe Tool Load Detect System constantly detects and diagnoses the tool load under a process to prevent tool wear and damage, and to keep your machine and tools in optimal shape.

#### Load Detection Limit 1

##### Alarm + Feed Hold

> When the LIMIT 1 Alarm sounds, the system holds the feed and the machine goes into stand-by.

#### Load Detection Limit 2

##### Alarm + Machine Stop

> When the LIMIT 2 Alarm sounds, the system stops the machine, and must be reset to operate it.

### Thread Repair Function

The Thread Repair Function on the Manual Guide I screen gives you an option to repair a stripped thread.

Main cover pocket

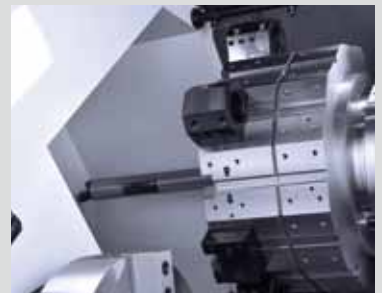

Rear Chuck Cover

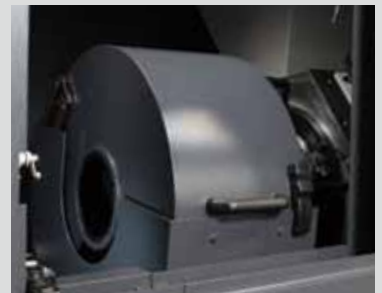

Best steady rest performance in its class(Optional)





Product Data : Hi-TECH 550BB

\* Unit: mm(inch)

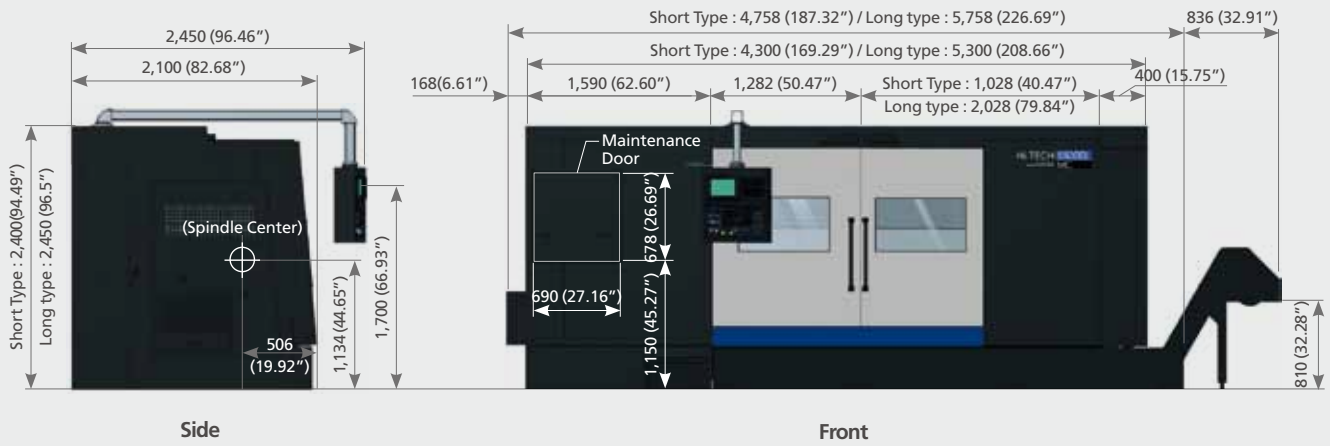

Spindle Power-Torque Diagram

Hi-TECH 550BB (Main Spindle)

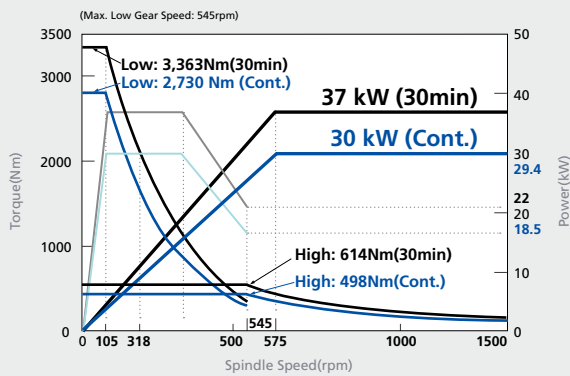

Hi-TECH 550BB (Turnmill)

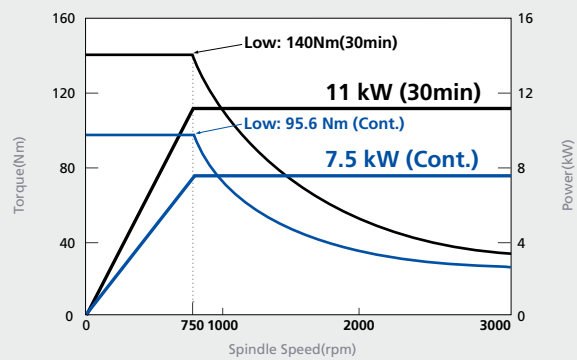

**Product Data : Hi-TECH 700BB/700BB\***

\* Unit: mm(inch)

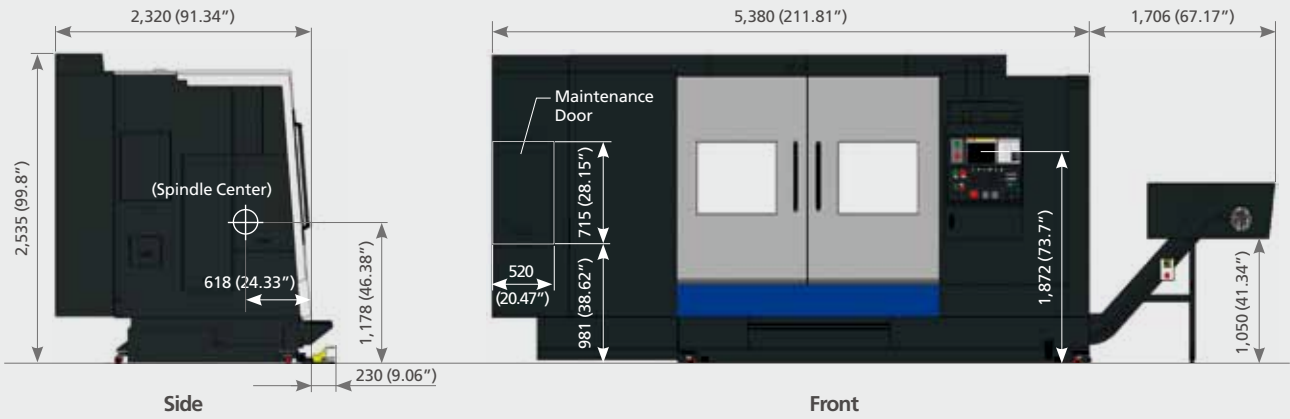

**Spindle Power-Torque Diagram**

Hi-TECH 700BB (Main Spindle)

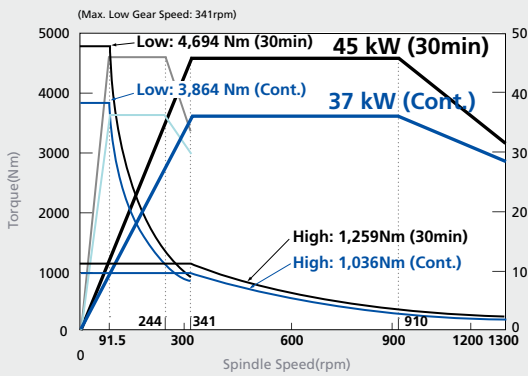

Hi-TECH 700BB\* (Main Spindle)

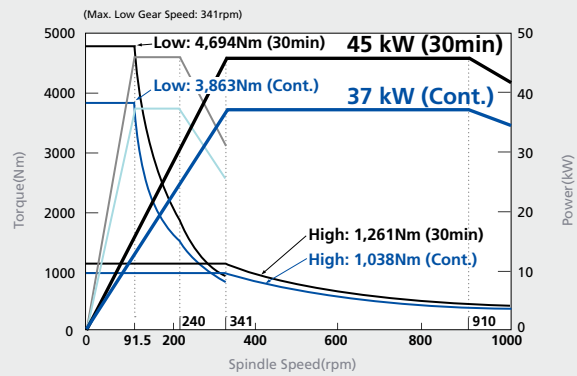

Hi-TECH 700BB/Hi-TECH 700BB\* (Turnmill)

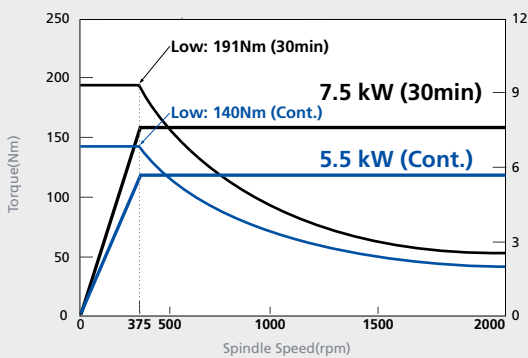

Product Data : Hi-TECH 850BB/850BB+

\* Unit: mm(inch)

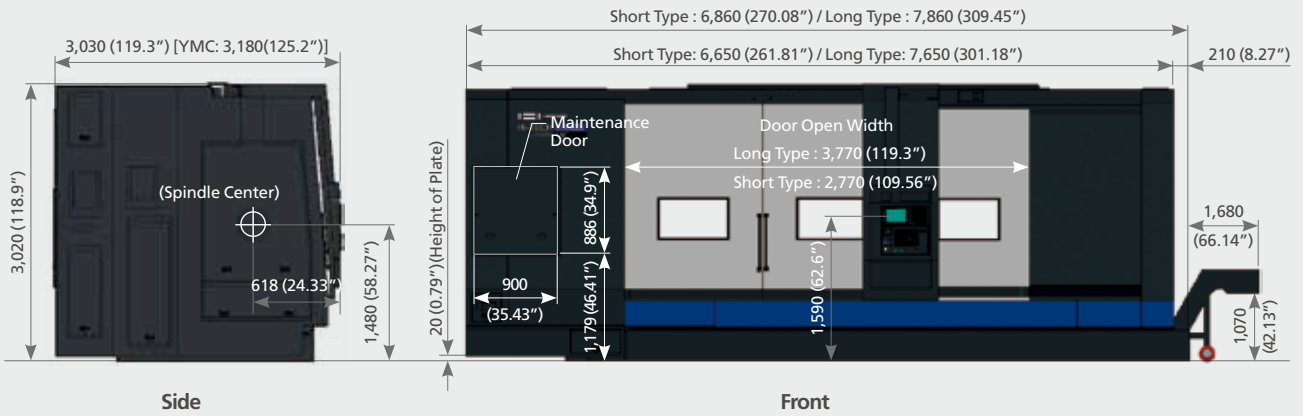

Spindle Power-Torque Diagram

Hi-TECH 850BB (Main Spindle)

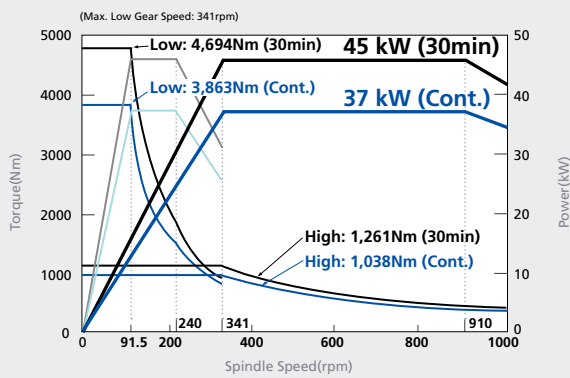

Hi-TECH 850BB+ (Main Spindle)

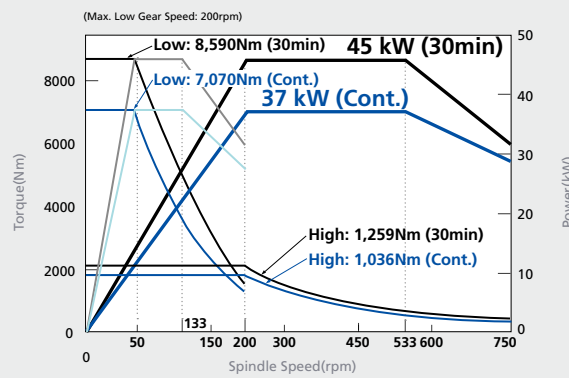

Hi-TECH 850BB/Hi-TECH 850BB+ (Turnmill)

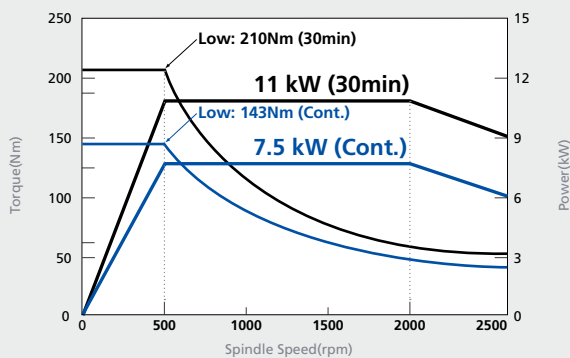



**Interference Diagram : Hi-TECH 550BB, Hi-TECH 700BB / 700BB\***

※ Unit : mm(inch)

**Hi-TECH 500BB STD**  
10 Station

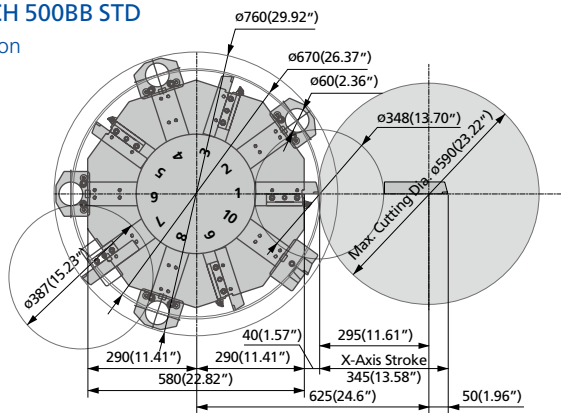

**Hi-TECH 500BB STD**  
12 Station

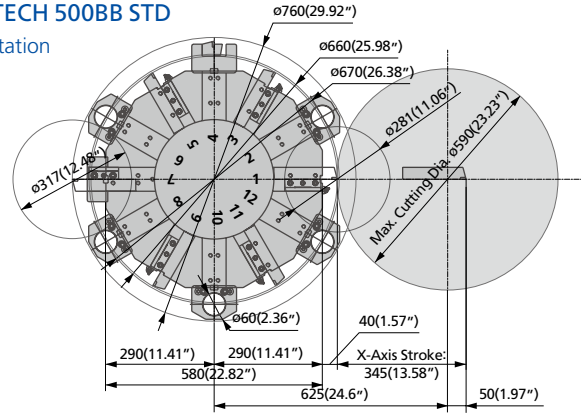

**Hi-TECH 500BB MC**

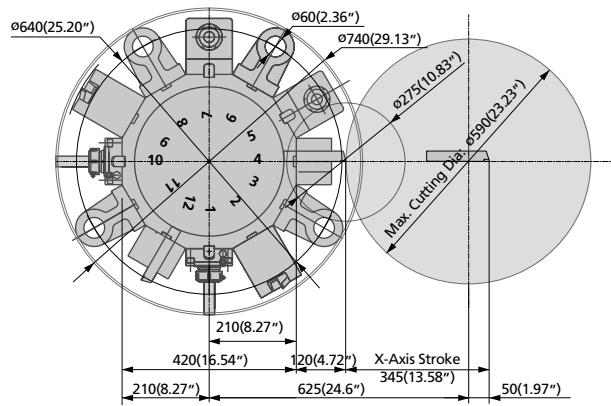

**Hi-TECH 700BB / 700BB\* STD**

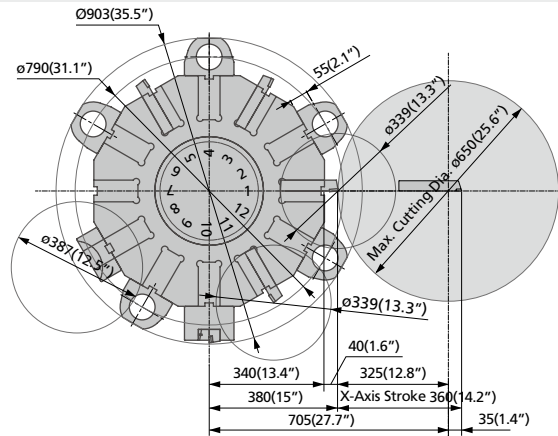

**Hi-TECH 700BB / 700BB\* MC**

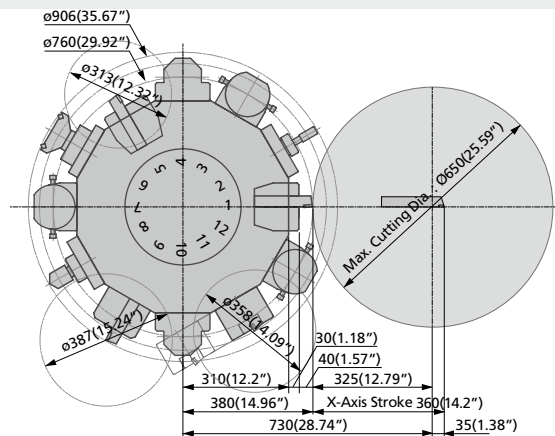

Interference Diagram : Hi-TECH 850BB, Hi-TECH 850BB+

※Unit: mm(inch)

Standard Tool Interference

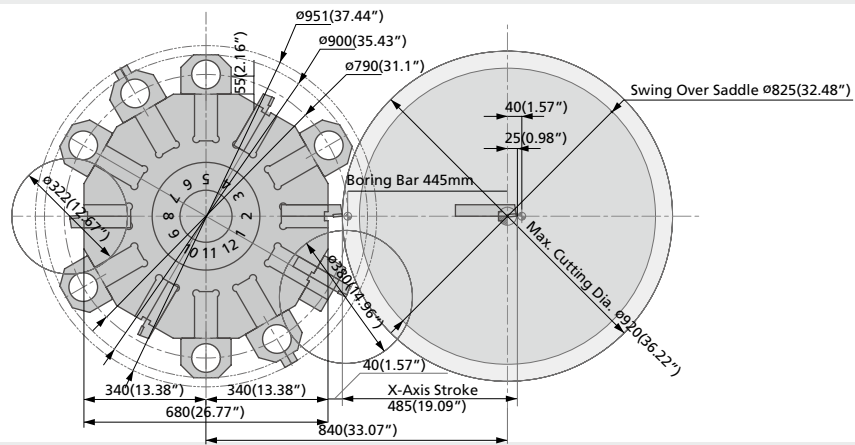

MC Tool Interference

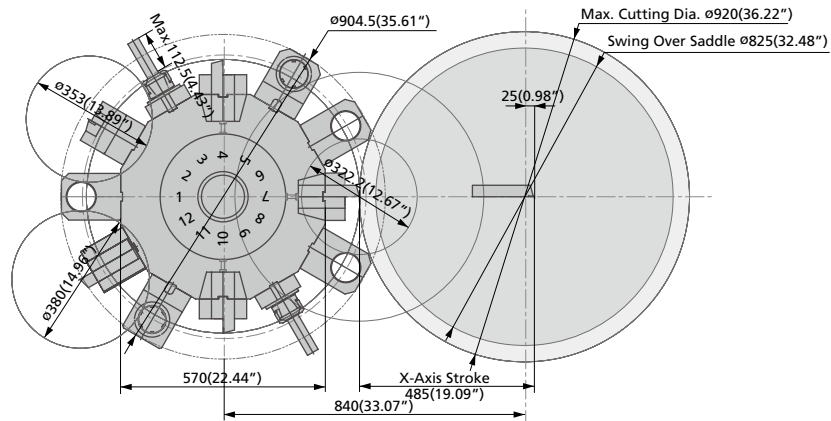

YMC Radial Turnmill Holder

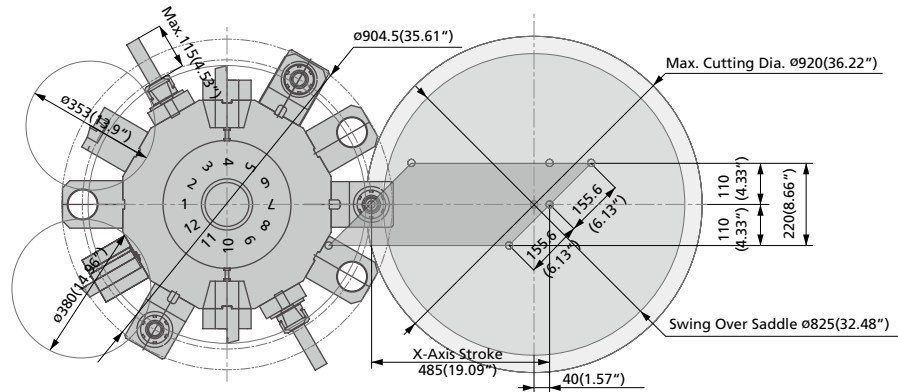

YMC Axial Turnmill Holder

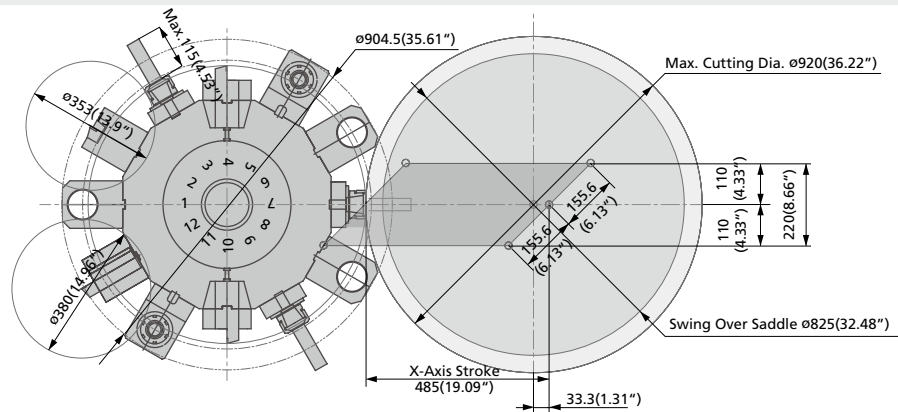

## Moving Range

### Hi-TECH 550BB

#### O.D Holder (Std.)

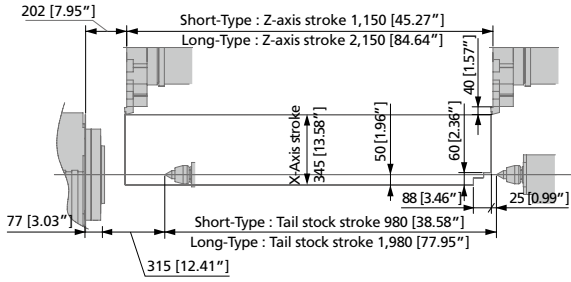

#### O.D Holder (MC)

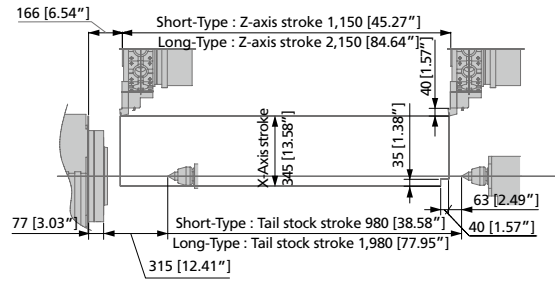

#### Radial Turnmill Holder

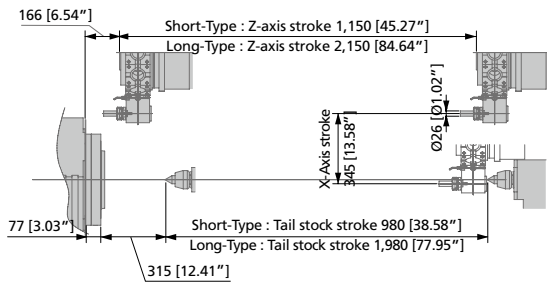

#### Axial Turnmill Holder

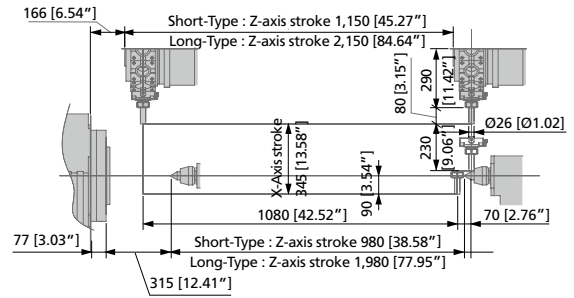

### Hi-TECH 700BB / 700BB+

#### O.D Holder

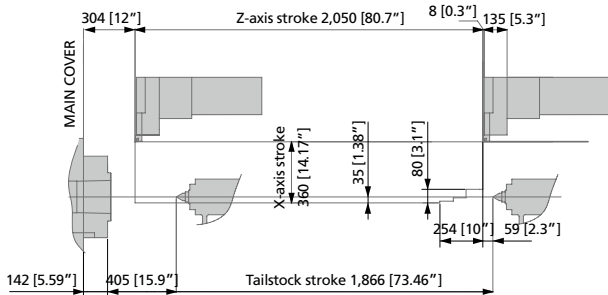

#### O.D Holder (MC)

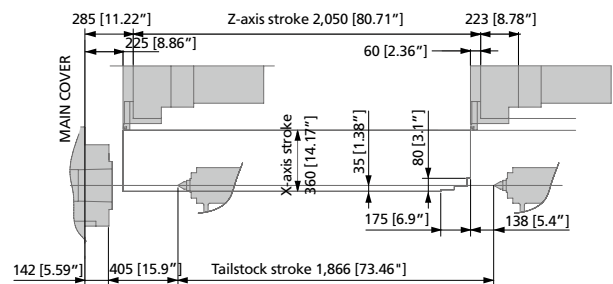

#### Radial Turnmill Holder

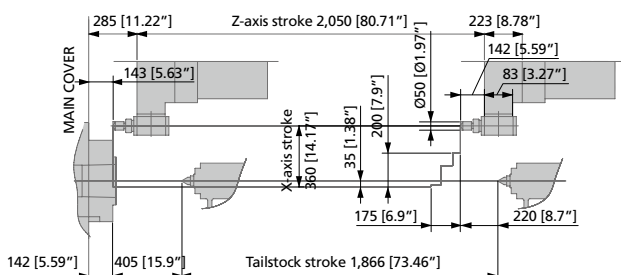

#### Axial Turnmill Holder

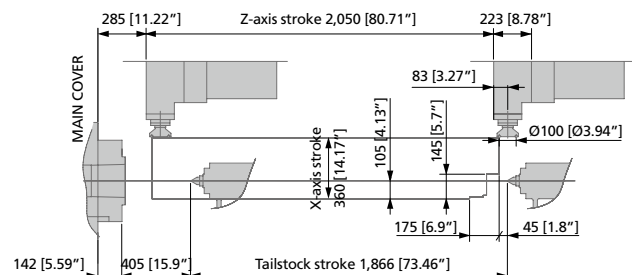



## Moving Range

### Hi-TECH 850BB / 850BB+

#### ID Holder (Std.)

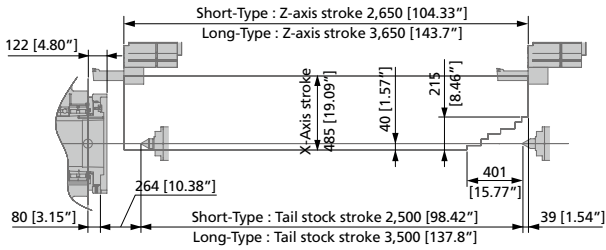

#### OD Holder (Std.)

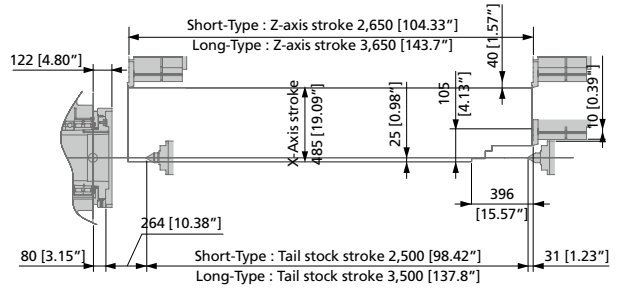

#### ID Holder (MC)

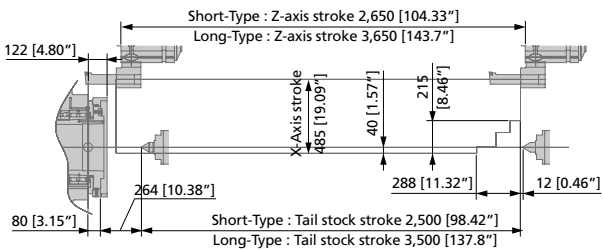

#### OD Holder (MC)

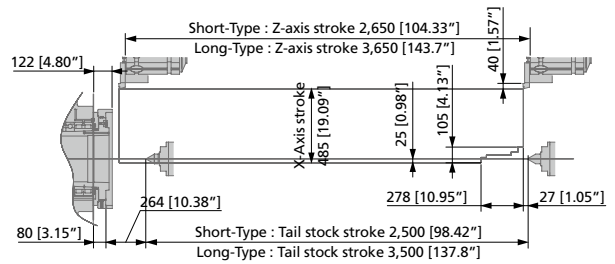

#### Radial Turnmill Holder

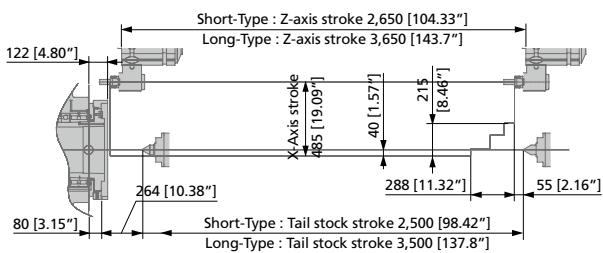

#### Axial Turnmill Holder

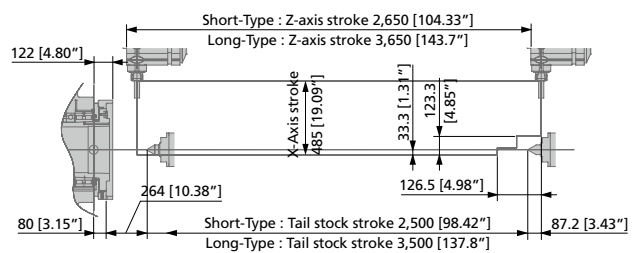

#### Extend O.D

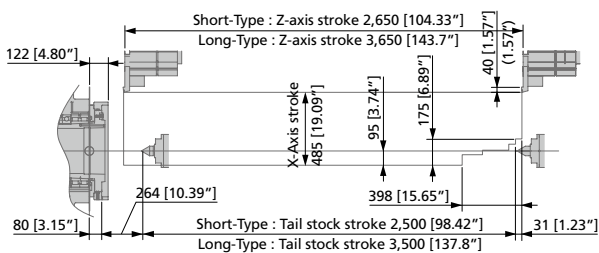

#### Long Boring Bar

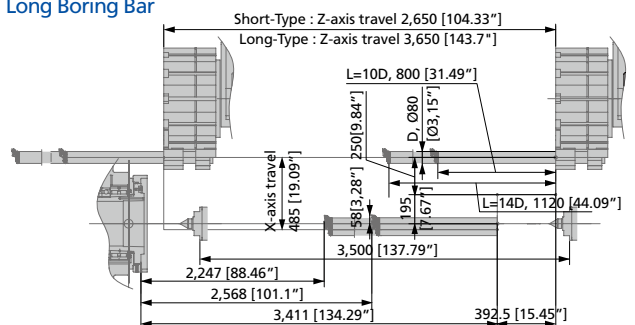

## Product Configuration

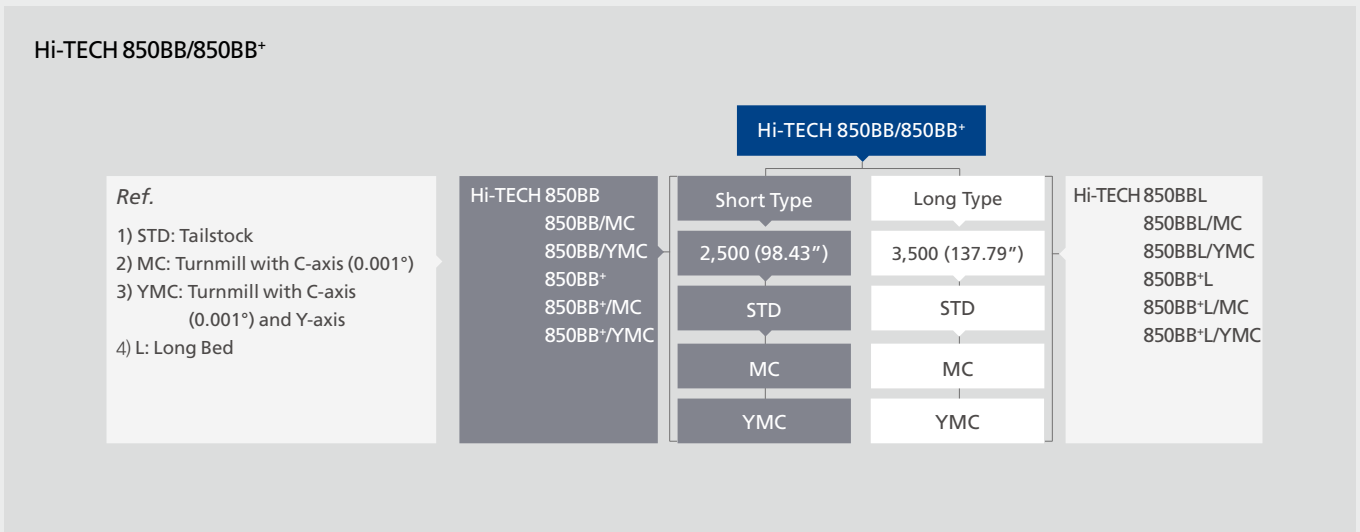
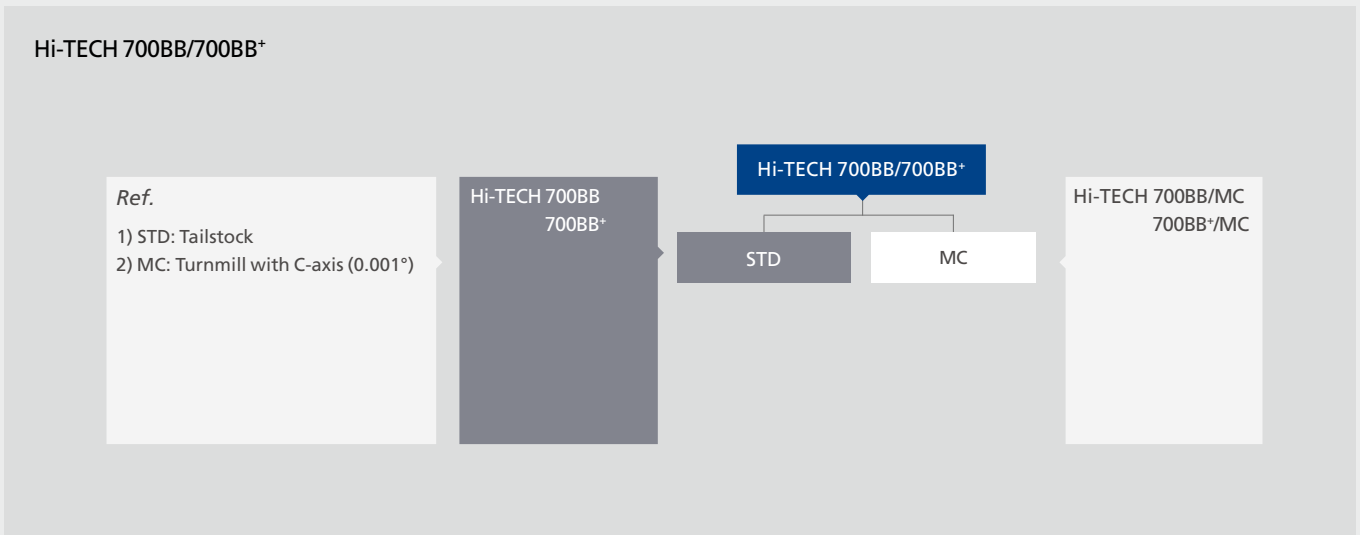
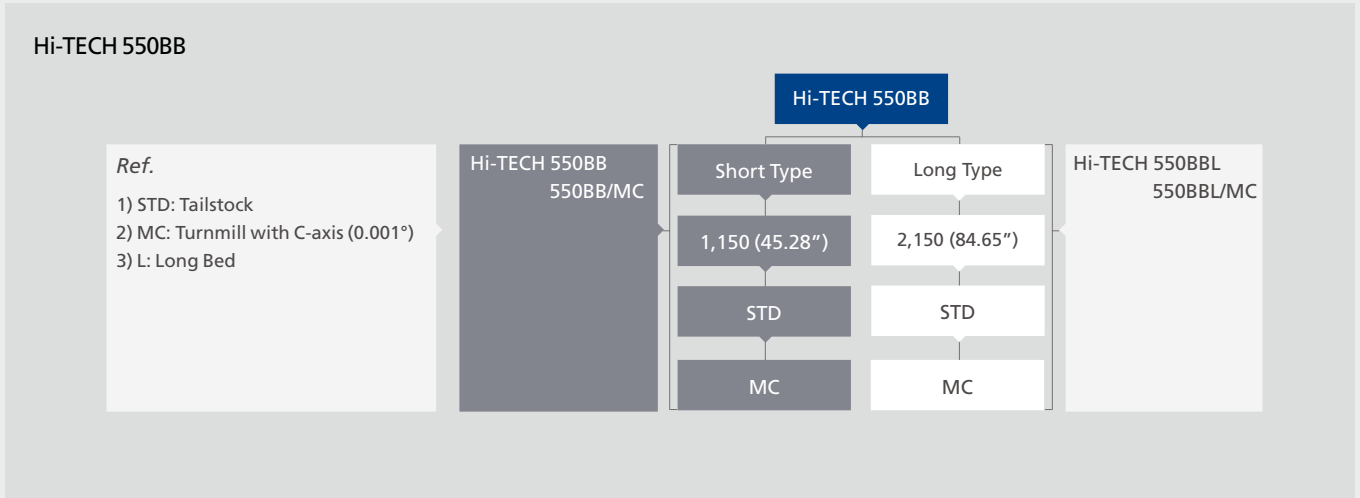

## Standard and Optional product components : Hi-TECH 550BB

Standard Accessories		Optional Accessories	
• Coolant System	• Tooling System	• Air Blower	• Tool Life Management
• Door Interlock	• Tool Kit & Box	• Air Chuck including Pneumatics Control System, SCHUNK/ SMW	• Tool Presetter (Automatic)
• Foot Switch	• Work Light	• Air Gun	• Tool & Work Counter - External/ Internal
• Hydraulic Unit	• ZF Gear Box	• Auto Door	• Transformer
• Leveling Bolt & Plate	• 10.4" LCD Display	• Chip Conveyor & Box (Side type)	• Turnmill Function Including C-axis (0.001°)
• Lubrication System		• Coolant Gun	• Turnmill Holder (Axial/ Radial)
• Manual Guide i		• High Pressure Pump System - 6bar/ 15bar/ 70bar	• Turnmill Spindle Motor Upgrade - 11/7.5kW
• Operation Manual & Parts List		• Linear Scale (X/ Z)	• U-Drill Holder
• Signal Lamp with 2 Colors (R, G)		• Manual Chuck, 20"	• Wide Type Turret Disk
• Standard Turret, 10 pos.		• NC Cooler	• Lathe-Hwacheon Tool Load Detect (L-HTLD)
• Tailstock, MT#5 - Tailstock Body Program - Tailstock Quill Program		• Oil Skimmer	
		• Signal Lamp with 3 Colors (R, G, Y)	
		• Standard Turret, 12 pos.	
		• Steady Rest Base Set	
		• Steady Rest Set, KHAN/ SMW	

## Standard and Optional product components : Hi-TECH 700BB, Hi-TECH 700BB\*

■ Hi-TECH 700BB ■ Hi-TECH 700BB\*

Standard Accessories		Optional Accessories	
• Coolant System	• Tooling System	• Air Blower	• Tool Life Management
• Door Interlock	• Tool Kit & Box	• Air Chuck including Pneumatics Control System, SCHUNK/ SMW	• Tool Presetter (Automatic)
• Foot Switch	• Work Light	• Air Gun	• Tool & Work Counter - External/ Internal
• Hydraulic Unit	• 10.4" LCD Display	• Chip Conveyor & Box (Side type)	• Transformer
• Leveling Bolt & Plate		• Coolant Gun	• Turnmill Function Including C-axis (0.001°)
• Lubrication System		• High Pressure Pump System - 6bar/ 15bar/ 70bar	• Turnmill Holder (Axial/ Radial)
• Manual Guide i		• Manual Chuck, 20"	• U-Drill Holder
• Operation Manual & Parts List		• Manual Chuck, 24"	• Wide Type Turret Disk
• Signal Lamp with 2 Colors (R, G)		• NC Cooler	• Lathe-Hwacheon Tool Load Detect (L-HTLD)
• Spindle Air Curtain		• Oil Skimmer	
• Standard Turret, 12 pos.		• Signal Lamp with 3 Colors (R, G, Y)	
• Steady Rest Base Set		• Steady Rest Base Set	
• Tailstock, MT#5 - Tailstock Body Program - Tailstock Quill Program		• Steady Rest Set, KHAN/ SMW	

## Standard and Optional product components : Hi-TECH 850BB, Hi-TECH 850BB\*

■ Hi-TECH 850BB ■ Hi-TECH 850BB\*

Standard Accessories		Optional Accessories	
• Door Interlock	• Tool Holder for Long Boring Bar, 1set	• Air Blower	• Tool Life Management
• Foot Switch	• Tooling System	• Air Chuck including Pneumatics Control System, SCHUNK/ SMW	• Tool Presetter (Automatic)
• High Pressure Coolant Pump, 6bar	• Tool Kit & Box	• Air Gun	• Tool & Work Counter - External/ Internal
• Hydraulic Unit	• Wide Type Turret Disk	• Chip Conveyor & Box (Side type)	• Transformer
• Leveling Bolt & Plate	• Work Light	• Coolant Gun	• Turnmill Function Including C-axis (0.001°)
• Lubrication System	• 10.4" LCD Display	• Function of Y-axis (±110mm)	• Turnmill Holder (Axial/ Radial)
• Manual Guide i		• High Pressure Pump System - 15bar/ 70bar	• U-Drill Holder
• Operation Manual & Parts List		• Linear Scale (X/ Z/ Y)	• Lathe-Hwacheon Tool Load Detect (L-HTLD)
• Signal Lamp with 2 Colors (R, G)		• Manual Chuck, 24"	
• Spindle Air Curtain		• Manual Chuck, 28"	
• Spindle Cooling System		• NC Cooler	
• Standard Turret, 12 pos.		• Oil Skimmer	
• Tailstock, MT#5 - Tailstock Body Program - Tailstock Quill Program		• Signal Lamp with 3 Colors (R, G, Y)	
		• Steady Rest Base Set	
		• Steady Rest Set, KHAN/ SMW	



## Machine Specifications

ITEM	Hi-TECH 550BB				
	550BB	550BB/MC	550BBL	550BBL/MC	
<b>Capacity</b>					
Swing over Bed	mm (inch)	Ø800 (Ø31.50")			
Max. Cutting Diameter	mm (inch)	Ø590 (Ø23.23")			
Standard Cutting Diameter	mm (inch)	Ø387 (Ø15.23")	Ø275 (Ø10.83")	Ø387 (Ø15.23")	Ø275 (Ø10.83")
Max. Cutting Length (Without Chuck)	mm (inch)	1,150 (45.27")		2,150 (84.64")	
Chuck Size (Opt.)	mm (inch)	Air chuck Ø470 (Ø18.5")			
<b>Spindle</b>					
Type of Spindle Nose	ASA	A2-15			
Max. Spindle Speed	rpm	1,500			
Through Spindle Hole Diameter	mm (inch)	Ø185 (Ø7.28")			
Max. Bar Size	mm (inch)	Ø180 (Ø7.08")			
Spindle Bearing Inner Diameter	mm (inch)	Ø240 (Ø9.45")			
Spindle Motor	kW (HP)	37/30 (50/40)			
<b>Turret</b>					
Number of Tool Station	ea	10 (Opt.: 12)	12	10 (Opt.: 12)	12
Tool Size (OD x ID)	mm (inch)	□32 x Ø60 (□1.25" x Ø2.5")			
Turret Indexing Time	sec / step	0.2			
<b>Feed rates</b>					
Rapid Speed (X / Z)	m/min (ipm)	20/24		20/20	
Max. Stroke (X / Z)	mm (inch)	345/1,150 (13.58"/45.28")		345/2,150 (13.58"/84.65")	
Feed Motor (X / Z)	kW (HP)	4/7(5.5/9.5)			
<b>Tailstock</b>					
Quill Dia.	mm (inch)	Ø120 (Ø4.72")			
Quill Stroke	mm (inch)	150 (5.91")			
Quill Taper	MT	# 5			
<b>Turnmill (Opt.)</b>					
Spindle Motor	kW (HP)	-	7.5/5.5 (10/7.5)	-	7.5/5.5 (10/7.5)
Max. Spindle Speed	rpm	-	4,000	-	4,000
Max. Drill / Collet Size	mm (inch)	-	Ø32(Ø1.26") /M20	-	Ø32(Ø1.26") /M20
Min. Index Angle	° (deg)	-	0.001°	-	0.001°
<b>Tank Capacity</b>					
Lubrication	ℓ (gal)	12(3.17)			
Hydraulic	ℓ (gal)	50(13.21)			
Coolant	ℓ (gal)	250(60)		380(100)	
<b>Power Sources</b>					
Electrical Power Supply	kVA	75			
<b>Dimension</b>					
Height	mm (inch)	2,400 (94.5")		2,450 (96.5")	
Floor Space (L x W)	mm (inch)	4,590 x 2,370 (180.7" x 93.3")		5,590 x 2,370 (220.1" x 93.3")	
Weight	kg(lb)	10,000 (22,046)	10,500 (23,148)	12,500 (27,558)	13,000 (28,660)
NC Controller	Fanuc 0i-TD				

## Machine Specifications

ITEM		Hi-TECH 700BB/700BB <sup>+</sup>			
		700BB	700BB/MC	700BB <sup>+</sup>	700BB <sup>+</sup> /MC
<b>Capacity</b>					
Swing over Bed	mm (inch)	Ø900 (Ø35.43")		Ø900 (Ø35.43")	
Max. Cutting Diameter	mm (inch)	Ø650 (Ø25.59")		Ø700 (Ø27.56")	
Standard Cutting Diameter	mm (inch)	Ø381 (Ø15")		Ø381 (Ø15")	
Max. Cutting Length (Without Chuck)	mm (inch)	2,050 (80.7")		2,050 (80.7")	
Chuck Size (Opt.)	mm (inch)	Air chuck Ø470 (Ø18.5")		Air chuck Ø630 (Ø24.8")	
<b>Spindle</b>					
Type of Spindle Nose	ASA	A2-15		A2-20	
Max. Spindle Speed	rpm	1,300		1,000	
Through Spindle Hole Diameter	mm (inch)	Ø185 (Ø7.28")		Ø300 (Ø11.81")	
Max. Bar Size	mm (inch)	Ø180 (Ø7.08")		Ø295 (Ø11.61")	
Spindle Bearing Inner Diameter	mm (inch)	Ø240 (Ø9.45")		Ø360 (Ø14.17")	
Spindle Motor	kW (HP)	45/37 (60/50)		45/37 (60/50)	
<b>Turret</b>					
Number of Tool Station	ea	12		12	
Tool Size (OD x ID)	mm (inch)	□32 x Ø60 (□1.25" x Ø2.5")		□32 x Ø60 (□1.25" x Ø2.5")	
Turret Indexing Time	sec / step	0.4		0.4	
<b>Feed rates</b>					
Rapid Speed (X / Z)	m/min (ipm)	18/18		18/18	
Max. Stroke (X / Z)	mm (inch)	360/2,050 (15.16"/81.5")		385/2,070 (15.16"/81.5")	
Feed Motor (X / Z)	kW (HP)	6/6 (8/8)		6/6 (8/8)	
<b>Tailstock</b>					
Quill Dia.	mm (inch)	Ø150 (Ø5.9")		Ø150 (Ø5.9")	
Quill Stroke	mm (inch)	150 (5.91")		150 (5.9")	
Quill Taper	MT	# 5		# 5	
<b>Turnmill (Opt.)</b>					
Spindle Motor	kW (HP)	-	7.5/5.5 (10/7.5)	-	7.5/5.5 (10/7.5)
Max. Spindle Speed	rpm	-	2,000	-	2,000
Max. Drill / Collet Size	mm (inch)	-	Ø32(Ø1.26") / M20	-	Ø50 (Ø2") / M24
Min. Index Angle	° (deg)	-	0.001°	-	0.001°
<b>Tank Capacity</b>					
Lubrication	ℓ (gal)	12 (3.17)		12 (3.2)	
Hydraulic	ℓ (gal)	50 (13.21)		50 (13.2)	
Coolant	ℓ (gal)	300 (79)		300 (79)	
<b>Power Sources</b>					
Electrical Power Supply	kVA	75		75	
<b>Dimension</b>					
Height	mm (inch)	2,535 (99.8")		2,535 (99.8")	
Floor Space (L x W)	mm (inch)	5,380x2,320 (211.9"x91.34")		5,380x2,320 (211.9"x91.34")	
Weight	kg(lb)	15,500 (34,172)	15,600 (34,392)	15,850 (34,943)	15,950 (35,164)
<b>NC Controller</b>		Fanuc Oi-TD			

## Machine Specifications

ITEM	Hi-TECH 850BB/850BB <sup>+</sup>												
	850BB	850BB /MC	850BB /YMC	850BBL	850BBL /MC	850BBL /YMC	850BB <sup>+</sup>	850BB <sup>+</sup> /MC	850BB <sup>+</sup> /YMC	850BB <sup>+</sup> L	850BB <sup>+</sup> L /MC	850BB <sup>+</sup> L /YMC	
<b>Capacity</b>													
Swing Over Bed	mm (inch)	Ø1,050 (Ø41.34")						Ø1,050 (Ø41.34")					
Max. Cutting Diameter (ØD x L)	mm (inch)	Ø920 (Ø36.22") [385 (15.16")]						Ø920 (Ø36.22") [385 (15.16")]					
Standard Cutting Diameter	mm (inch)	Ø380 (Ø14.96")						Ø380 (Ø14.96")					
Max. Cutting length (without chuck)	mm (inch)	2,650 (104.33")			3,650 (143.7")			2,650 (104.33")			3,650 (143.7")		
Chuck Size (Opt.)	mm (inch)	Air Chuck Ø630 (Ø24.8")						Air Chuck Ø850 (Ø33.5")					
<b>Spindle</b>													
Type of Spindle Nose	ASA	A2-20						A2-20					
Max. Spindle Speed	rpm	1,000						750					
Through Spindle Hole Diameter	mm (inch)	Ø300 (Ø11.81")						Ø375 (Ø14.76")					
Max. Bar Size	mm (inch)	Ø295 (Ø11.61")						Ø370 (Ø14.56")					
Spindle Bearing Inner Diameter	mm (inch)	Ø360 (Ø14.17")						Ø440 (Ø17.32")					
Spindle Motor	kW (HP)	45 / 37 (60 / 50)						45 / 37 (60 / 50)					
<b>Turret</b>													
Number of Tool Station	ea	12						12					
Tool Size (OD x ID)	mm (inch)	□32 x Ø80 (□1.25" x Ø3")						□32 x Ø80 (□1.25" x Ø3")					
Turret Indexing Time	sec / step	0.3						0.3					
<b>Feed rates</b>													
Rapid Speed (X / Z / Y)	m/min (ipm)	10/12/- (393.7/472.4/-)	10/12/10 (393.7/472.4 /393.7)	10/10/- (393.7/393.7/-)	10/10/10 (393.7/393.7 /393.7)	10/12/- (393.7/472.4/-)	10/12/10 (393.7/472.4 /393.7)	10/10/- (393.7/393.7/-)	10/10/10 (393.7/393.7 /393.7)				
Max. Stroke (X / Z / Y)	mm (inch)	485/2,650/- (19.1"/104.33" /-)	485/2,650/220 (19.1"/104.33" /8.66")	485/3,650/- (19.1"/143.7" /-)	485/3,650/220 (19.1"/143.7" /8.66")	485/2,650/- (19.1"/104.33" /-)	485/2,650/220 (19.1"/143.7" /8.66")	485/3,650/- (19.1"/143.7" /-)	485/3,650/220 (19.1"/143.7" /8.66")				
Feed Motor (X / Z / Y)	kW (HP)	6/6/- (8/8/-)	6/6/7 (8/8/9.3)	6/6/- (8/8/-)	6/6/7 (8/8/9.3)	6/6/- (8/8/-)	6/6/7 (8/8/9.3)	6/6/- (8/8/-)	6/6/7 (8/8/9.3)				
<b>Tailstock</b>													
Quill Dia.	mm (inch)	Ø160 (Ø6.3")						Ø160 (Ø6.3")					
Quill Stroke	mm (inch)	150 (5.91")						150 (5.91")					
Quill Taper	MT	# 6						# 6					
<b>Turnmill (Opt.)</b>													
Spindle Motor	kW (HP)	-	11/7.5 (15/10)	-	11/7.5 (15/10)	-	11/7.5 (15/10)	-	11/7.5 (15/10)				
Max. Spindle Speed	rpm	-	2,500	-	2,500	-	2,500	-	2,500				
Max. Drill / Collet Size	mm (inch)	-	Ø32 (Ø1.25") /ER50	-	Ø32 (Ø1.25") /ER50	-	Ø32 (Ø1.25") /ER50	-	Ø32 (Ø1.25") /ER50				
Min. Index Angle	° (deg)	-	0.001°	-	0.001°	-	0.001°	-	0.001°				
<b>Tank Capacity</b>													
Lubrication	ℓ (gal)	12(3.7)						12(3.7)					
Hydraulic	ℓ (gal)	50(13)						50(13)					
Coolant	ℓ (gal)	400 (105.67)			550 (145.3)			400 (105.67)			550 (145.3)		
<b>Power Sources</b>													
Electrical Power Supply	kVA	75						75					
<b>Dimension</b>													
Height	mm (inch)	3,020 (118.9")						3,020 (118.9")					
Floor Space (L x W)	mm (inch)	6,860 x 3,030 (270.08" x 119.3")	6,860 x 3,180 (270.08" x 125.2")	7,860 x 3,030 (309.45" x 119.3")	7,860 x 3,180 (309.45" x 125.2")	6,860 x 3,030 (270.08" x 119.3")	6,860 x 3,180 (270.08" x 125.2")	7,860 x 3,030 (309.45" x 119.3")	7,860 x 3,180 (309.45" x 125.2")				
Weight	kg(lb)	18,000 (39,683)	18,500 (40,785)	19,500 (42,990)	23,000 (50,706)	23,500 (51,808)	24,500 (54,013)	18,500 (40,785)	19,000 (41,887)	20,000 (44,092)	23,500 (51,808)	24,000 (52,910)	25,000 (55,116)
<b>NC Controller</b>													
Fanuc 0i-TD													



## NC Specifications [Fanuc0i-TD]

※ - : Not available S : Standard O : Option

ITEM	SPECIFICATION	STD	MC	YMC
Controlled axis				
Controlled axis (Cs axis)	2-Axes	2-Axes	3-Axes	4-Axes
Simultaneously controlled axes	2-Axes	2-Axes	3-Axes	4-Axes
Least input increment	0.001mm, 0.001deg, 0.0001inch	S	S	S
Least input increment 1/10	0.0001mm, 0.0001deg, 0.00001inch	O	O	O
inch/metric conversion	G20, G21	S	S	S
Stored stroke check 1		S	S	S
Stored stroke check 2,3		S	S	S
Mirror image		S	S	S
Backlash compensation		S	S	S
Operation				
Automatic & MDI operation		S	S	S
Program number search		S	S	S
Sequence number search		S	S	S
Dry run, single block		S	S	S
Manual handle feed	1Unit	S	S	S
Manual handle feed rate	x1, x10, x100	S	S	S
Interpolation function				
Positioning	G00	S	S	S
Linear interpolation	G01	S	S	S
Circular interpolation	G02, G03	S	S	S
Dwell (Per seconds)	G04	S	S	S
Polar coordinate interpolation	G12.1/G13.1	-	S	S
Cylindrical interpolation	G7.1	-	S	S
Threading / Continuous threading	G32	S	S	S
Multiple threading / Threading Retract		S	S	S
Variable lead threading	G34	S	S	S
Reference position return 1st	G28	S	S	S
Reference position return check	G27	S	S	S
2,3,4th reference position return	G30	S	S	S
Feed function				
Rapid traverse override	F0, F25, F50, F100	S	S	S
Feed per minute (mm/min)	G98	S	S	S
Feed per revolution (mm/rev)	G99	S	S	S
Rapid traverse bell-shaped acceleration/deceleration		S	S	S
Feedrate override	0-150 %	S	S	S
Jog feed override	0-1,260 mm/min	S	S	S
Tool function / compensation				
Tool function	T4-digits	S	S	S
Tool offset pairs	64 pairs	S	S	S
Tool nose radius compensation		S	S	S
Tool geometry / wear compensation		S	S	S
Tool life management		O	O	O
Automatic tool offset	Tool presetter option is required	O	O	O
Direct input tool offset value measured B	Tool presetter option is required	O	O	O
Others				
Display unit	10.4" Color LCD	S	S	S

※ YMC: Hi-TECH 850BB/ Hi-TECH 850BB\*

ITEM	SPECIFICATION	STD	MC	YMC
Program input				
Tape code	EIA RS244 / ISO840	S	S	S
Optional block skip	1ea	S	S	S
Program number	O4-Digits	S	S	S
Sequence number	N5-Digits	S	S	S
Decimal point programming		S	S	S
Coordinate system setting	G50	S	S	S
Coordinate system shift		S	S	S
Workpiece coordinate system	G54-G59	S	S	S
Workpiece coordinate system preset	G92.1	S	S	S
Direct drawing dimension programming		S	S	S
G code system	A	S	S	S
Programmable data input	G10	S	S	S
Sub program call	10Folds Nested	S	S	S
Custom macro B		S	S	S
Addition of custom macro -common variables	#100-#199, #500-#999	S	S	S
Canned cycles		S	S	S
Multiple repetitive cycle		S	S	S
Multiple repetitive cycle II		S	S	S
Canned cycles for drilling		S	S	S
Manual guide i		S	S	S
Spindle speed function				
Constant surface speed control	G96 / G97	S	S	S
Spindle override	50-120 %	S	S	S
Spindle orientation		S	S	S
Rapid tapping		O	S	S
Editing operation				
Part program storage length	1,280m (512 kB)	S	S	S
Number of register able programs	400ea	S	S	S
Background editing		S	S	S
Extended part program editing		S	S	S
Play back		S	S	S
Operation / Display				
Clock function		S	S	S
Self-diagnosis function		S	S	S
Alarm history display		S	S	S
Help function		S	S	S
Run hour and parts count display		S	S	S
Graphic function		S	S	S
Multi-language display	Korean, English, German, French, Italian, Chinese, Spanish, Portuguese, Polish, Hungarian, Swedish, Russian	S	S	S
Data input/output				
Reader / Puncher interface CH1	RS232C	S	S	S
Reader / Puncher interface CH2	RS232C	S	S	S
Ethernet interface		S	S	S
Memory card interface		S	S	S

## Hwacheon Global Network

 Hwacheon Headquarter  Hwacheon America  Hwacheon Europe  Hwacheon Asia

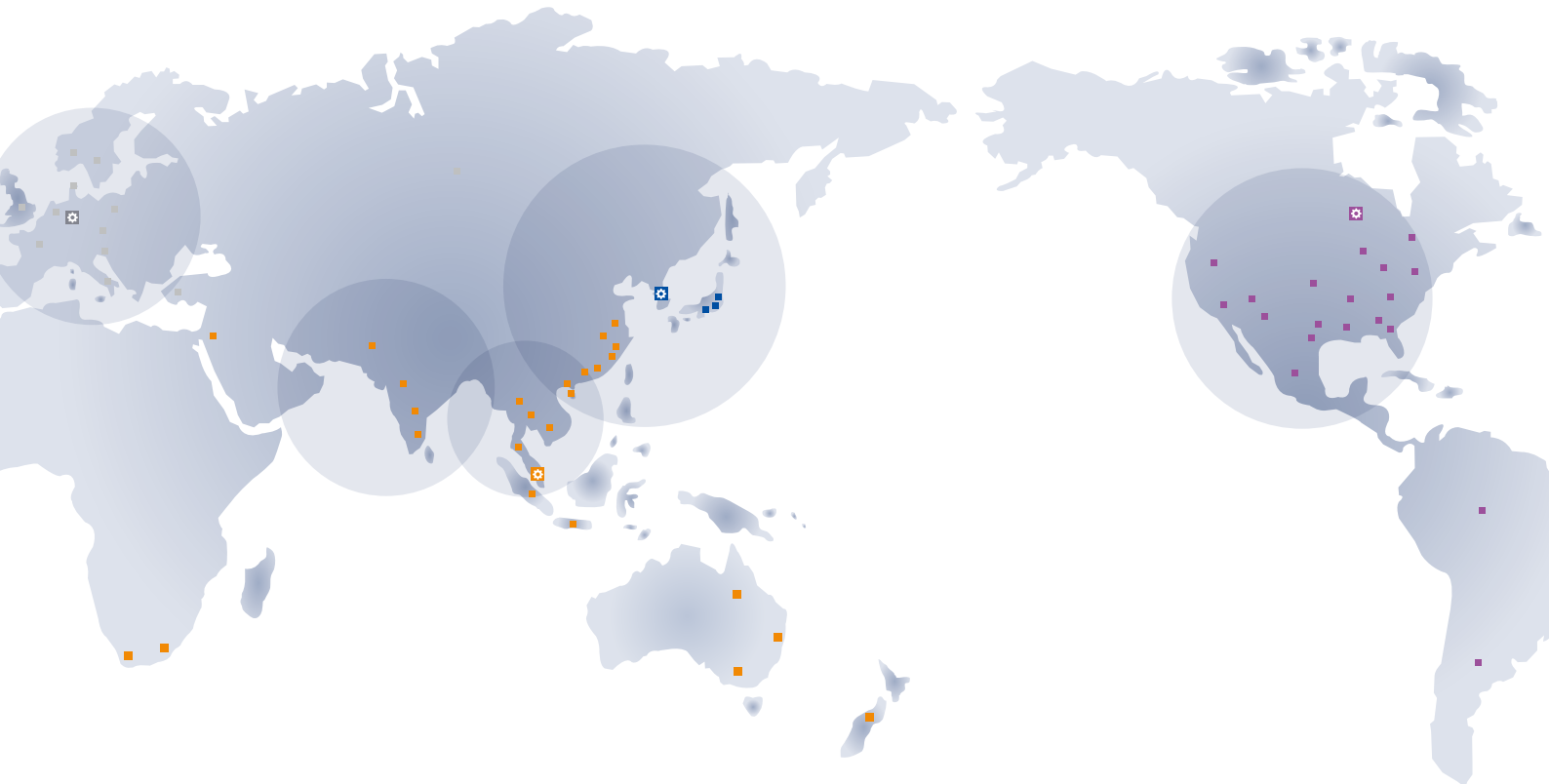

**HWACHEON**

Please call us for product inquiries.

[www.hwacheon.com](http://www.hwacheon.com)

The product design and specifications may change without prior notice.  
Read the operation manual carefully and thoroughly before operating the product,  
and always follow the safety instructions and warnings labels attached on the surfaces of the machines.

### HEAD OFFICE

#### HWACHEON MACHINE TOOL CO., LTD

976-1, JANGDEOK-DONG GWANGSAN-GU, GWANGJU, KOREA  
TEL: +82-62-951-5111 FAX: +82-62-951-0086

### SEOUL OFFICE

1022-7, BANGBAE-DONG, SEOCHO, SEOUL, KOREA  
TEL: +82-2-523-7766 FAX: +82-2-523-2867

### USA

#### HWACHEON MACHINERY AMERICA, INC.

50, LAKEVIEW PARKWAY VERNON HILLS, IL60061, USA  
TEL: +1-847-573-0100 FAX: +1-847-573-9900

### SINGAPORE

#### HWACHEON ASIA PACIFIC PTE. LTD.

21 BUKIT BATOK CRESCENT, #08-79 WCEGA TOWER SINGAPORE 658065  
TEL: +65-6515-4357 FAX: +65-6515-4358

### GERMANY

#### HWACHEON MACHINERY EUROPE GMBH

JOSEF-BAUMANN STR. 25, 44805, BOCHUM, GERMANY  
TEL: +49-2349-128160 FAX: +49-2349-128166